

METAL ROOFING TOOLS

PRODUCT

Spotlight



Single Handle Tool - Various Sizes Available
(20", 19", 17.25", 15.25", 11.25")

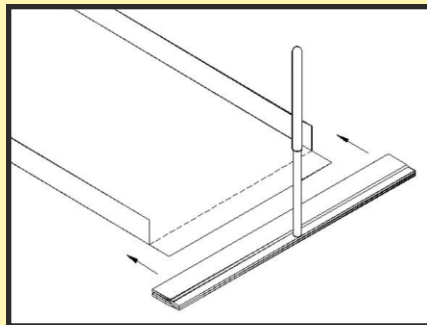

Step 1 - notch panel ribs
and slide tool
on panel

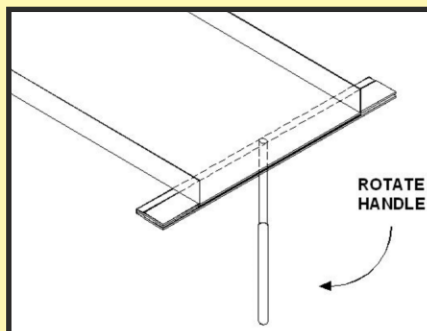

Step 2 - rotate tool handle
to form hem

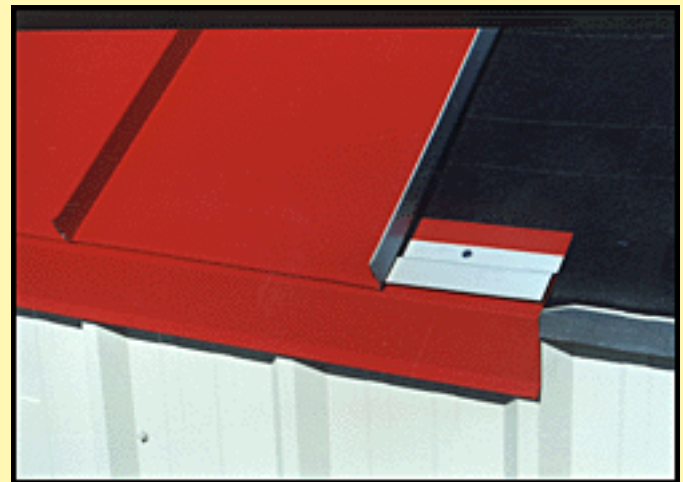

Form the perfect hem



Wide Handle - 24" Tool



Serving the Metal Roofing Industry for over 28 years

QUALITY, PERFORMANCE, & AFFORDABLE

13125 Deer Lake Dr. , Memphis, IN 47143

Phone (812) 248-4788

www.metalttools.com